

ROFUN RACING

www.rofunracing.com



Instructions

1:5 4WD RACING TRUCK

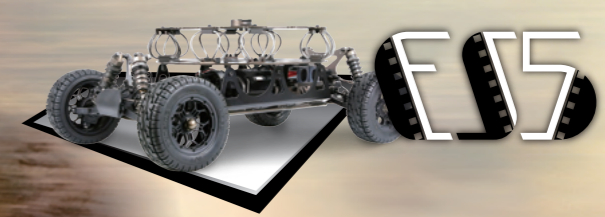



8711806

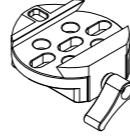

68103

68070

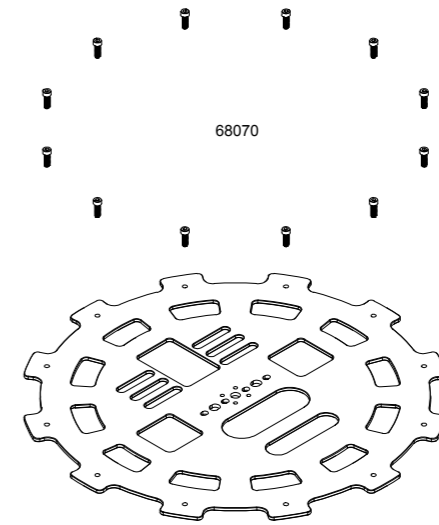

68038

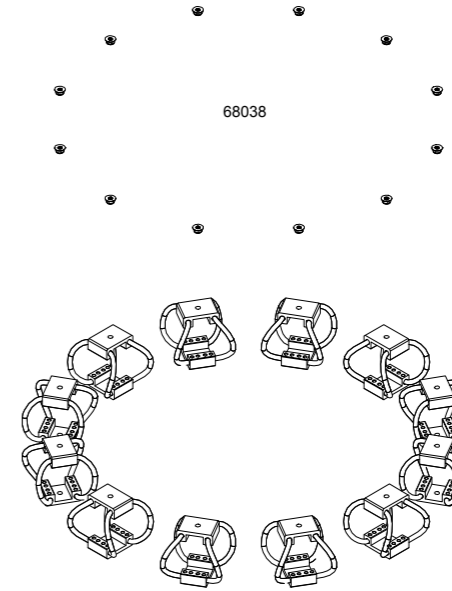

68070

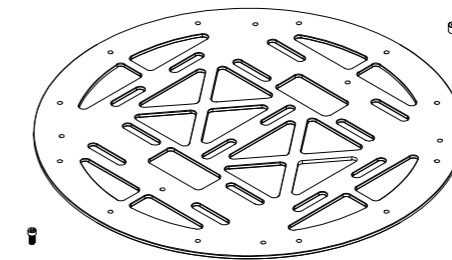

68038

68070

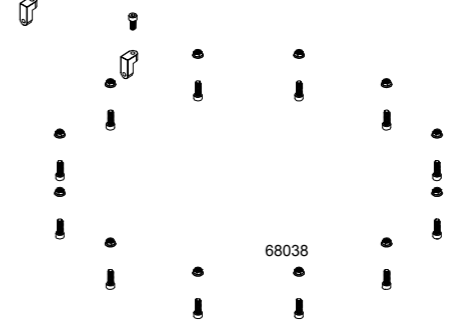

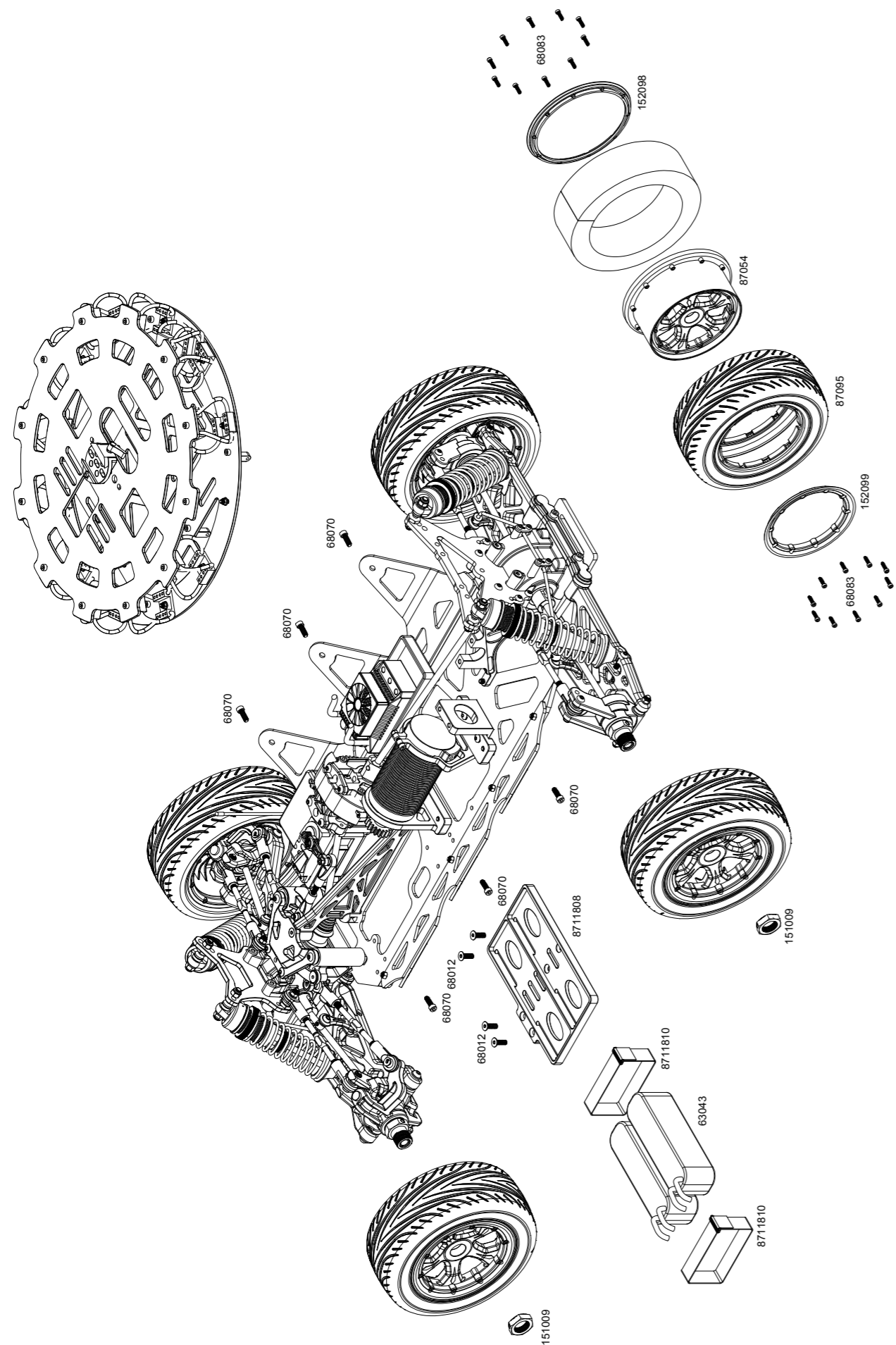

欢迎使用本公司 LT 系列产品。此产品采用高品质材料生产，设计新颖，操作有趣。仔细阅读说明将有助于您更加容易的操控此产品。我们愿与您分享操控的乐趣与刺激。

Welcome to use our company's LT series products. It's produced with high-quality materials, with novel design and interesting operation. Reading the instructions carefully will help you control this product more easily. We would like to share the joy and excitement with you.

Attention  不按照此说明操作有可能会损害整车或零配件，甚至导致人身伤害。
If you don't follow the manual to run the vehicle, which may cause the probability of truck damage, collateral spare parts damage and even serious bodily injury.

Attention  不按照此说明操作有可能伤害到自己或他人。
Failure to follow this instruction may cause the hurt to yourself and others.

Caution 

- 为了防止造成人身伤害或财产损失，操控此车时请特别注意。此车采用可燃性混合汽油燃料，最高速度可达70km/h。
To prevent any serious personal injury and/or damage to property, please be responsible when operating this vehicle. This vehicle uses inflammable mixed gasoline. Max running speed of this vehicle would reach 70km/h.
- 14岁以下儿童、禁止玩耍。
Children are forbidden to play under 14 years old.

发动机安全操作指南 Engine Guidelines for safe handling

- 请加入汽油与两冲程机油混合燃料。
Please use a mixture of gasoline and 2stroke oil for fuel.
- 请勿在有火苗和烟区操控此车或加油。
Never operate your vehicle near open flames. Never smoke while operating your vehicle or while handling fuel.
- 加油时保持水平位置，远离火苗、火源、高温等地方。
When fueling the vehicle, please be sure to make this vehicle be in a well horizontal site, and away from flame and high temperature area.
- 此发动机仅用汽油与两冲程机油混合作为燃料，其它燃料均不可使用。
Only use a mixture of gasoline and twocycle oil for fuel in this vehicle. Do not use other fuel.
- 汽油易燃有毒，请注意安全。
Please be safe because gasoline is inflammable and poisonous.
- 操控过程中有些部件温度很高，在未冷却之前请勿触摸。
Do not touch the engine and muffler as they can become extremely hot during use.
- 使用完毕后将油箱的剩余燃料清理掉。
Please clean the fuel tank after running this vehicle.
- 操控时远离儿童。
Please be away from children when running this vehicle.

装箱清单 Packing List

- RC整车 RC assembled car
- 遥控/接收机 Transmitter/Receiver
- 接收机电池 Receiver battery
- 工具/说明书 Tool/Instruction
- 充电器 Charger

公司可能会对箱内配件做其它的调整, 不再另行通知, 一切以收到的实物为准。
ROFUN might do some changes on accessories, which would not be informed. Please just subject to all what you get.

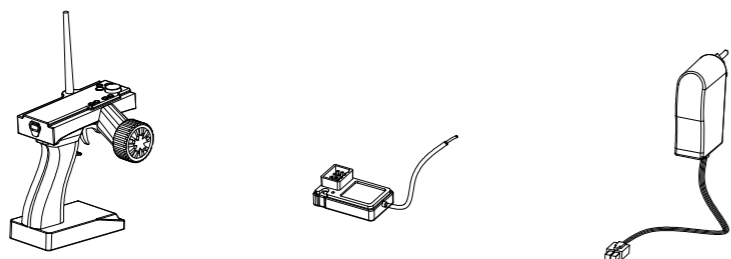

遥控设备或其它配件会出现更新与图片不符, 恕不另行通知, 解释权归公司所有。

Transmitter equipment or other spare parts might be updated in future, which maybe not same as current picture. We won't make extra informing. ROFUN own the reserved explanation right for all instructions and terms.

配备工具 Fitted Tools

- | | | | | | | |
|----------------------|----------------------|----------------------------|-----------------------------|-------------------------------|-------------------------------|----------------------|
| 六角扳手
Allen wrench | 十字套筒
Cross Wrench | 火花塞套筒
Spark plug wrench | 金属六角扳手
Metal Hexagon key | 塑料六角扳手
Plastic Hexagon key | 燃油配比壶
Mixed fuel ratio can | 轮毂扳手
Wheel Wrench |
|----------------------|----------------------|----------------------------|-----------------------------|-------------------------------|-------------------------------|----------------------|

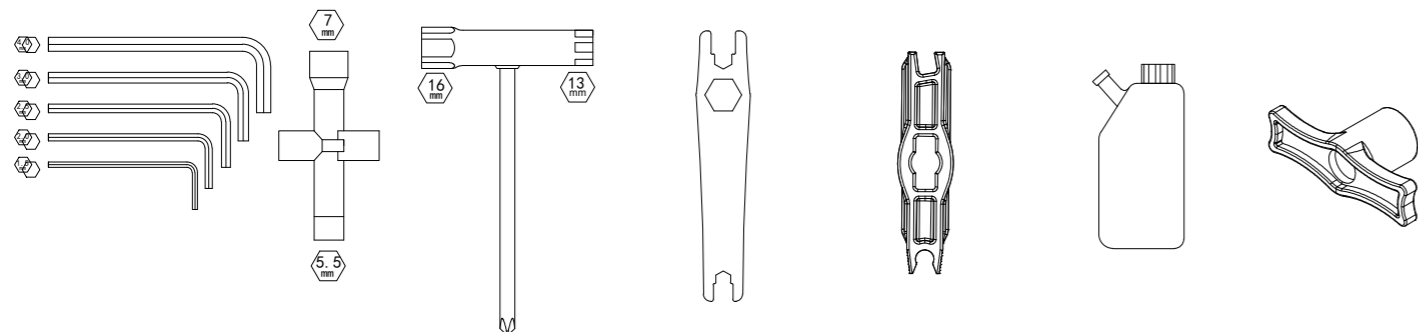

自备工具 Self-prepared Tools

- 一字螺丝刀
Screwdriver

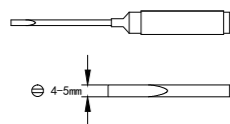

- AA电池
AA Battery

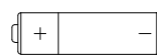

- 燃油壶
Gasoline

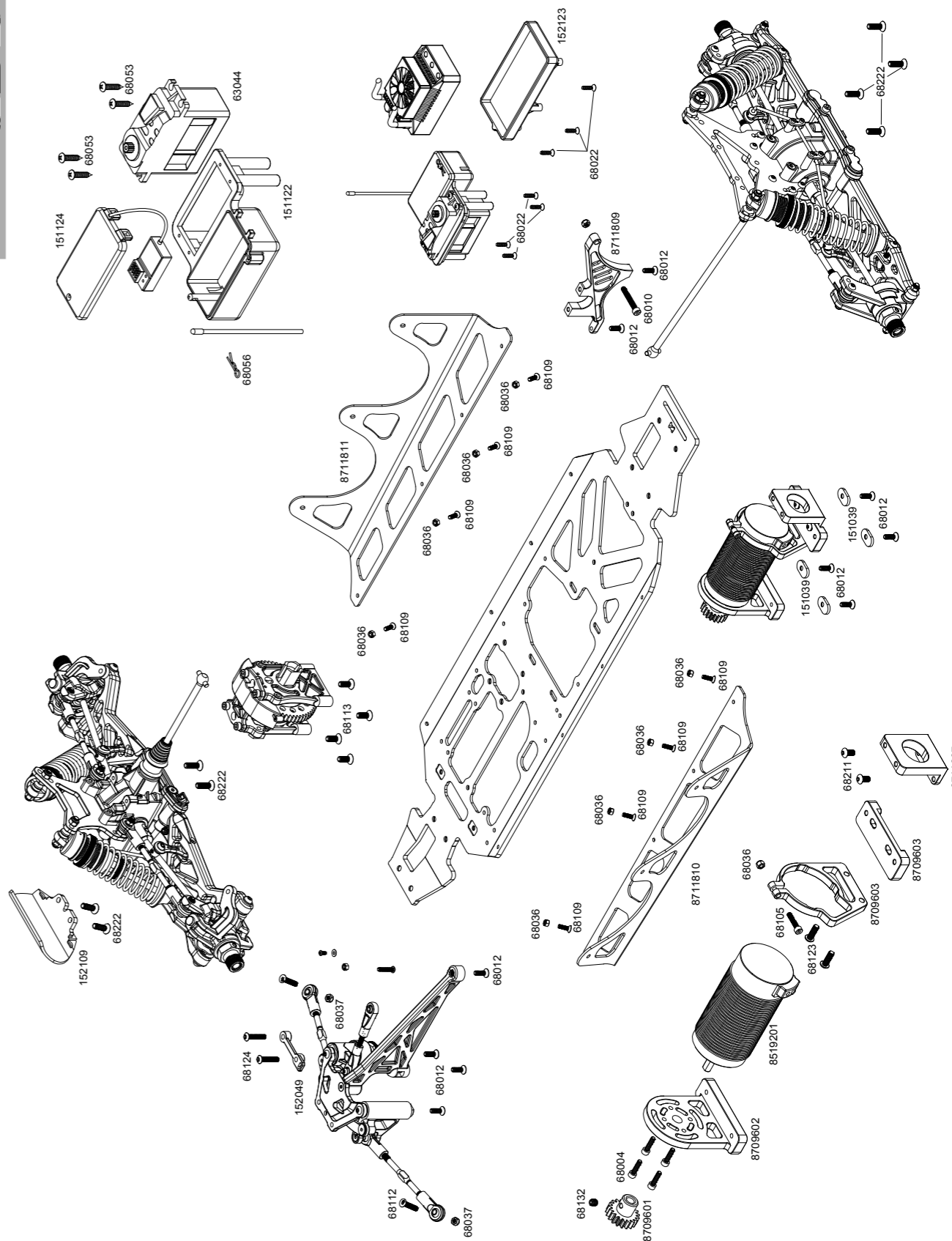
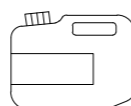

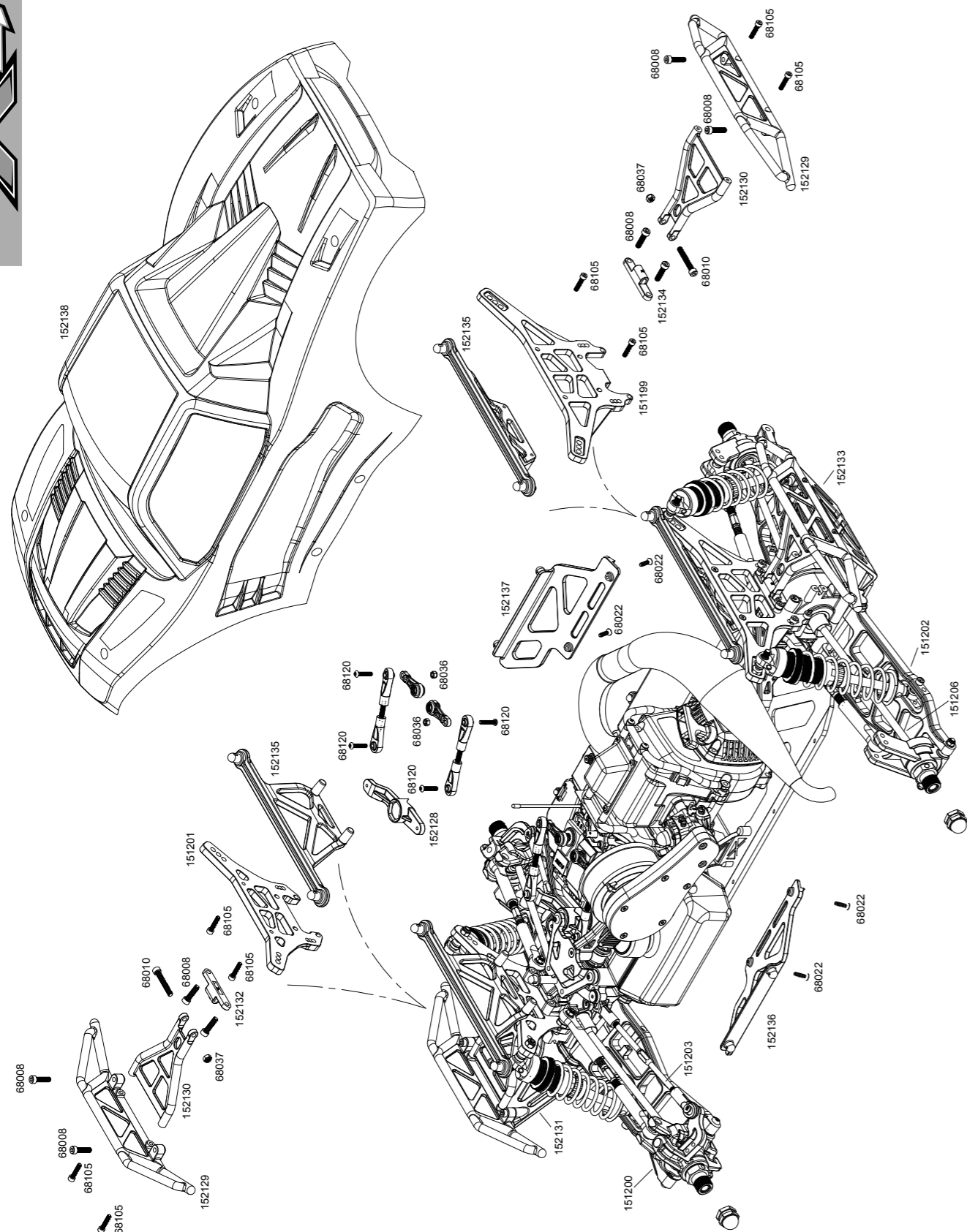

发动机磨合 *Engine running-in*

通过在地面慢速小油门行驶（约一箱的燃料）来磨合发动机。

Please run this vehicle slowly on the ground (about a tank of fuel) to make engine running-in.



- 不要在磨缸的时候调整化油器设定。这样做将导致发动机损坏。
Don't adjust the setup of original carburetor, otherwise will damage the engine.
- 请勿触摸发动机和消声器，因为他们在使用过程中会变得非常热。
Please don't touch engine and muffler, because they will become very hot during the running.
- 切勿停止发动机之前关闭发射器或接收器的电源。您将失去对您车辆的控制。
Please don't close transmitter and receiver power before stopping engine, otherwise you will lose control of vehicle.

按下熄火开关来关闭发动机
Push this fire-off switch to stop engine

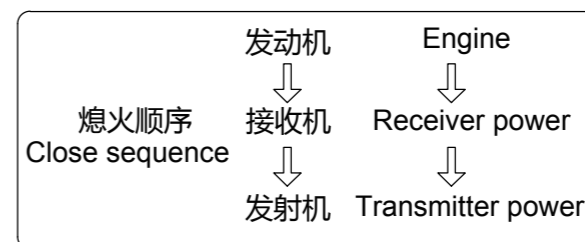
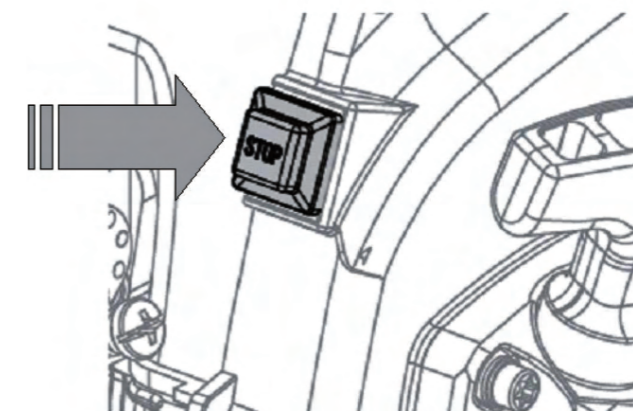

发动机保养小常识 *Engine Maintenance*

- 要经常清洗发动机空滤海绵，并且在每次清洗完后，自然风干，并抹上适量的空滤油。
The air filter foam need to be cleaned very often. After finishing cleaning, please just let it dry naturally and re-oiled properly.
- 火花塞要定期的拆下来清洗，将电极上的积碳清理干净。
Spark plug also need to be cleaned regularly, and clean all carbon deposit on the electrode.
- 如果长时间不玩车，请将油箱内的燃油倒干净，点燃发动机，让其自动熄火。
please empty the gasoline in the fuel tank, light the engine and make it shut down automatically if you don't run the vehicle for a very long time.

车辆启动 *Vehicle Starting And Running*

启动顺序 发射机 ⇨ 接收机 ⇨ 发动机
 Startup sequence Transmitter power ⇨ Receiver power ⇨ Engine

启动发动机 Priming The Engine

发动机必须吸入燃油才可以成功启动。按压吸油气囊，直到你可以看到燃料从回油管返回到油箱内。
 The engine must be primed before it can be successfully started. Push the primer bulb until you can see fuel in the yellow return tube.

启动程序：冷启动 Starting Procedure: Cold Engine

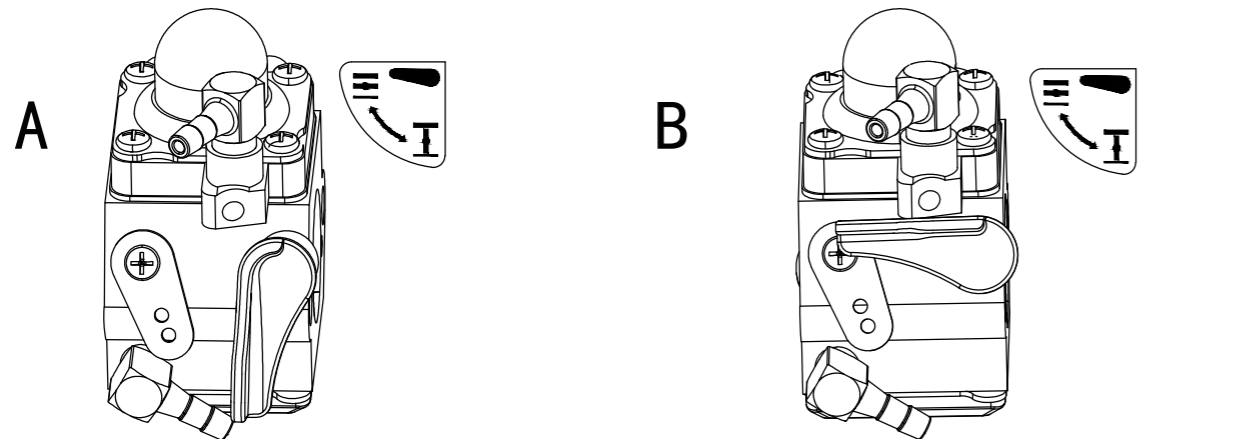

1. 设置阻风阀手柄，如步骤A所示。
Set choke lever as shown in Step A
2. 连续拉动启动器拉线（约3次），直到你听到发动机几乎启动，然后停止。
Pull start cord in a quick continuous motion (about 3 times) until you hear the engine almost start, then stop.
3. 小心不要让燃料涌入发动机。不拉超过50cm/20英寸，否则会破坏拉动启动装配。
Be careful not to flood the engine with fuel. Do not pull more than 50 cm/20 inch or you can damage the pull start assembly.
4. 设置阻风阀手柄，如步骤B所示。
Set the choke lever as shown in Step B.
5. 拉动手拉启动器，启动发动机。
Pull the starter cord start the engine.
6. 发动机应该在6次拉动内启动。
The engine should start within 6 pulls.

启动程序：热启动 Starting Procedure: Hot Engine

1. 设置阻风阀手柄，如步骤B所示。
Set the choke lever as shown in Step B.
2. 连续快速拉动发动机启动手拉线。发动机应该在6次拉动内启动。
Pull the starter cord in a quick continuous motion to start the engine. The engine should start within 6 pulls.

